

10Ft Deluxe Horseshoe (4) 1x3 Kits + (1) 3x3 Kit

Full display systems are offered in a wide choice of configurations from basic tabletop kits to full 20' long displays. All systems are offered as curved or straight systems, single or double sided and offer the option of combining with either breath taking seamless graphic mural panels or versatile "Velcro friendly" fabric panels. (Magnetic booths include a graphic mural that replace the fabric panels)

Standard production time line for these products (1-5 Ct.) is 4-6 days.

Standard production time line for detachable graphics for fabric display (50-100 sq. ft.) is 2-4 days.

Booth Structure Specs:

Frame Color: Purple

Standard Fabric Color: Blue

- Standard Horseshoe Kit:**
- (1) 3X3 frame
 - (4) 1X3 frame
 - (42) channel bars,
 - (7) straight fabric panels
 - (2) end cap fabric panels
 - (2) linking fabric panels
 - (2) ghost fabric panels
 - (2) OCP case
 - (3) 200 Watt Lights

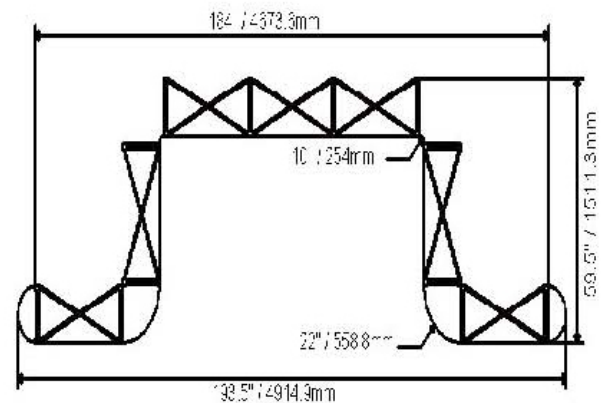

Structure Overall Size: 193.5"W x 60"D x 87.5625" H

Shipping Size: 39"W x 26"D x 16" H OCP Case

Shipping Weight: 160 lbs.

Cases: (2) Black OCP

Panel Specs: *Straight Panel:* 28.8125"wide x 87.5625"high

End Cap Panel: 23.5"wide x 87.5625"high

Linking Panel: 22"wide x 87.5625"high

Ghost Panel: 10"wide x 87.5625"high

Graphic Type: Pos-Pro/Polycarb combo with hook velcro

Graphic Sizes: (7) *Straight Panels:* 28.8125"wide x 87.5625"high

+ (2) *End Cap Panel:* 23.5"wide x 87.5625"high

+ (2) *Linking Panel:* 22"wide x 87.5625"high

+ (2) *Ghost Panel:* 10"wide x 87.5625"high

Horseshoe Kit

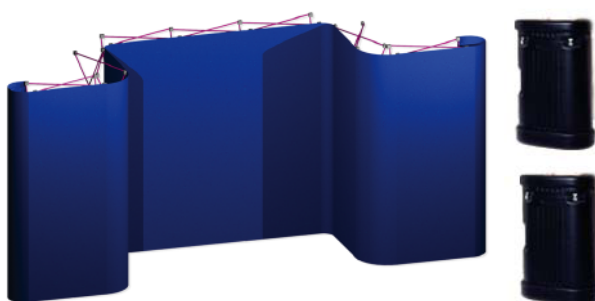

Horseshoe Graphics Kit

